

NEWS 68

Components for pneumatic automation

Valves and Solenoid valves

Poppet system

N776 Series



PNEUMAX GREEN LINE: TECHNOLOGY & INNOVATION

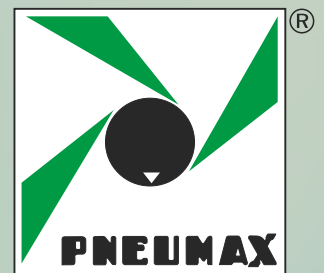

www.pneumaxspa.com



General

The N776 G1.1/2" series of valves and solenoid operated poppet valves is the result of the technical evolution of the 776 series. A rolling diaphragm construction has replaced the previously used piston design ensure lower frictions and longer life. Connection 3 is isolated via a dedicated seal which allow to have the N.O. version as well as the self feed for vacuum which was not available on the 776 series.

The pilot valves are the M3R (CNOMO Stile) with bistable manual override.

Coils are not included and have to be ordered separately (see 300 series, 22mm MB coils and 30mm CNOMO MC coils).

Coils C RU US homologated are also available. (series 300).

Construction characteristics

Body, operator and end cover:	Die casting Aluminium
Seals and poppets:	NBR oil resistant rubber
Piston:	Aluminium (for Air) - Acetylic resin (for Vacuum)
Pin guide:	Nickel plated steel
Spring:	Steel
Diaphragm:	NBR oil resistant rubber

Use and maintenance

Under correct working conditions the average life of this series of valves is 10 - 15 million cycles. Lubrication is not required but correct air filtration is recommended.

It is also important to ensure that the application parameters are in line with those indicated in the technical specification of this product: pressure, temperature....

The valves, thanks to their construction design, do not require maintenance involving replacement of parts; when necessary it is possible to carefully clean and remove any dirt that might have accumulated internally.

When using the internal pilot version, both for air or vacuum, it is necessary to ensure that the downstream flow rate is lower than the inlet flow rate. Should the flow requirement match or exceed the inlet flow rate the pressure / vacuum inside the valve would drop below the minimum value necessary to actuate the pilot valve. This is a normal scenario on poppet valves as without pilot, not having a closed centre position, the valve would exhaust from port 3.

For applications where downstream flow rate requirements can match or exceed inlet flow rate use externally piloted valves

Air valves port layout:		Vacuum valves port layout:	
Normally Closed:	1 = LINE IN	Normally Closed internal Pilot	1 = EXHAUST
	2 = CONSUMPTION	Normally Open (servoassisted) external pilot	2 = CONSUMPTION
	3 = EXHAUST		3 = PUMP
Normally Open:	1 = EXHAUST	Normally Open internal Pilot	1 = PUMP
	2 = CONSUMPTION	Normally Closed servoassisted) external pilot	2 = CONSUMPTION
	3 = LINE IN		3 = EXHAUST

**Minimum working pressure diagram
for external pilot versions
Normally Closed & Normally Open**

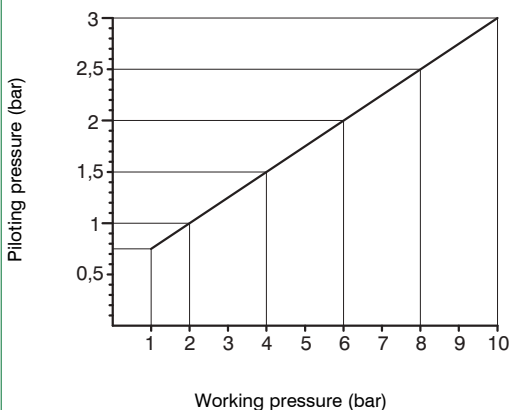

Pneumatic - Spring

Ordering code
N776.22.11.1C

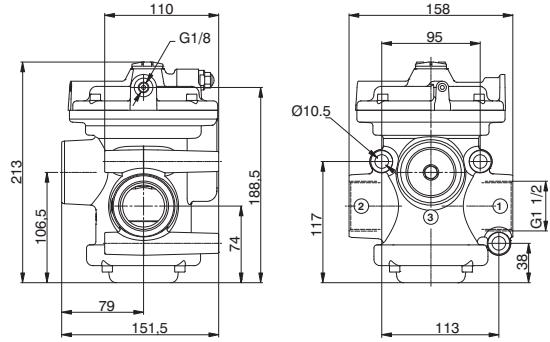

Weight gr.3560
Normally Closed
Minimum piloting pressur "See diagram on the General page"

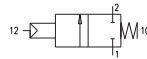

Operational characteristics	Fluid	Temperature °C	Max working pressure (bar)	Flow rate at 6 bar with Δp=1 (NI/min)	Orifice size (mm)	Working ports size	Pilot ports size
	Filtered and lubricated air	-5 ÷ +70	10	33500	38	G1 1/2"	G1/8"

Solenoid - Spring

Ordering code
N776.22.0.F.M3R
FUNCTION
F 1AC = Internal Pilot Normally Closed
1C = External Pilot Normally Closed

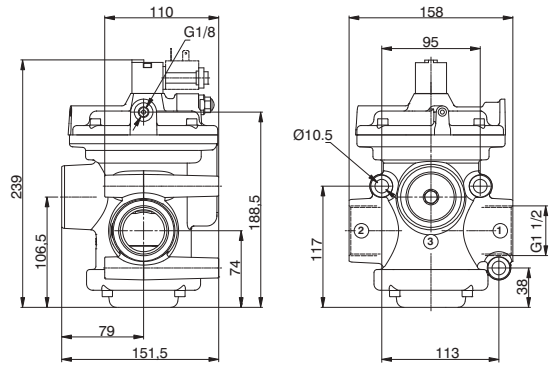

Weight gr.3620
Minimum working pressure: Servoassisted external pilot version, "See diagram on the General page" / 3,5 bar Internal pilot version,



Operational characteristics	Fluid	Temperature °C	Max working pressure (bar)	Flow rate at 6 bar with Δp=1 (NI/min)	Orifice size (mm)	Working ports size	Pilot ports size
	Filtered and lubricated air	-5 ÷ +50	10	33500	38	G1 1/2"	G1/8"

Pneumatic - Spring

Ordering code
N776.32.11.1

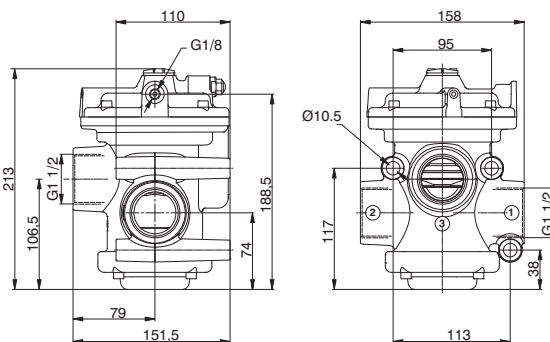

Weight gr.3550
Normally Closed / Normally open
Minimum piloting pressur "See diagram on the General page"



Operational characteristics	Fluid	Temperature °C	Max working pressure (bar)	Flow rate at 6 bar with Δp=1 (NI/min)	Orifice size (mm)	Working ports size	Pilot ports size
	Filtered and lubricated air	-5 ÷ +70	10	33500	38	G1 1/2"	G1/8"

Solenoid - Spring

Ordering code
N776.32.0.F.M3R
FUNCTION
1AC = Internal Pilot Normally Closed
F 1AA=Internal Pilot Normally Open
1 = External Pilot Normally Closed-Normally Open

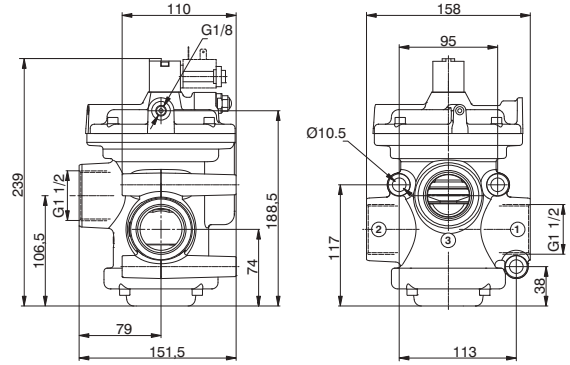

Weight gr.3610
Minimum working pressure: Servoassisted external pilot "See diagram on the General page" / 3,5 bar Internal pilot version,

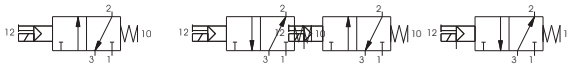

Operational characteristics	Fluid	Temperature °C	Max working pressure (bar)	Flow rate at 6 bar with $\Delta p=1$ (Nl/min)	Orifice size (mm)	Working ports size	Pilot ports size
	Filtered and lubricated air	-5 ÷ +50	10	33500	38	G1 1/2"	G1/8"

Pneumatic - Spring

Ordering code
N776/V.22.11.1C

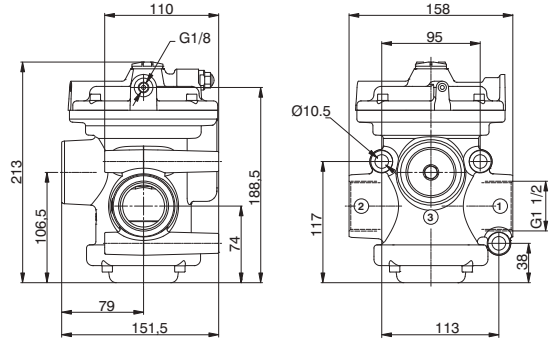

Weight gr.3178
Normally Closed
Minimum piloting pressur 2 bar

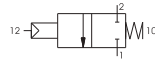

Operational characteristics	Fluid	Temperature °C	Orifice size (mm)	Working ports size	Pilot ports size
	Vacuum	-5 ÷ +70	38	G1 1/2"	G1/8"

Solenoid - Spring

Ordering code
N776/V.22.0.Ⓜ.M3R
FUNCTION
Ⓜ 1AC = Internal Pilot Normally Closed
Ⓜ 1C = External Pilot Normally Closed

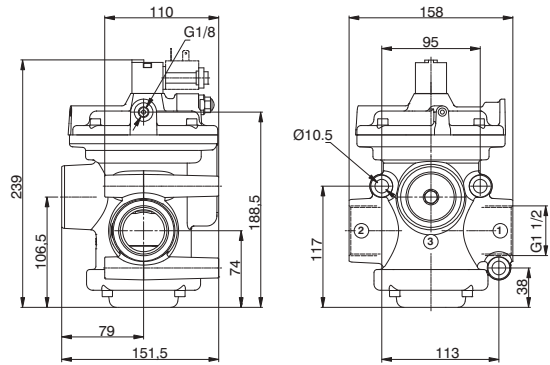

Weight gr.3238
Minimum working pressure 2 bar



Operational characteristics	Fluid	Temperature °C	Orifice size (mm)	Working ports size	Pilot ports size
	Vacuum	-5 ÷ +50	38	G1 1/2"	G1/8"

Pneumatic - Spring

Ordering code
N776/V.32.11.1

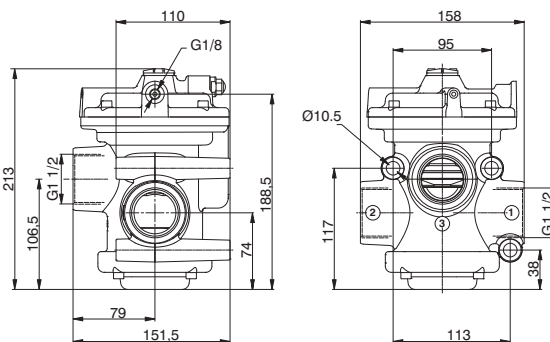

Weight gr.3168
Normally Closed / Normally open
Minimum piloting pressur 2 bar

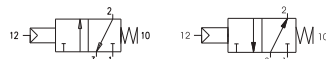

Operational characteristics	Fluid	Temperature °C	Orifice size (mm)	Working ports size	Pilot ports size
	Vacuum	-5 ÷ +70	38	G1 1/2"	G1/8"

Solenoid - Spring

Ordering code
N776/V.32.0.F.M3R
FUNCTION
1AC = Internal Pilot Normally Closed
F 1AA=Internal Pilot Normally Open
1 = External Pilot Normally Closed-Normally Open

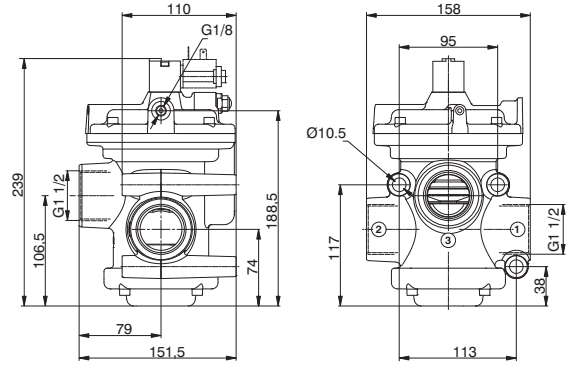

Weight gr.3228
Minimum working pressure 2 bar

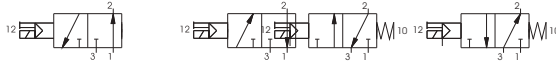

Operational characteristics	Fluid	Temperature °C	Orifice size (mm)	Working ports size	Pilot ports size
	Vacuum	-5 ÷ +50	38	G1 1/2"	G1/8"

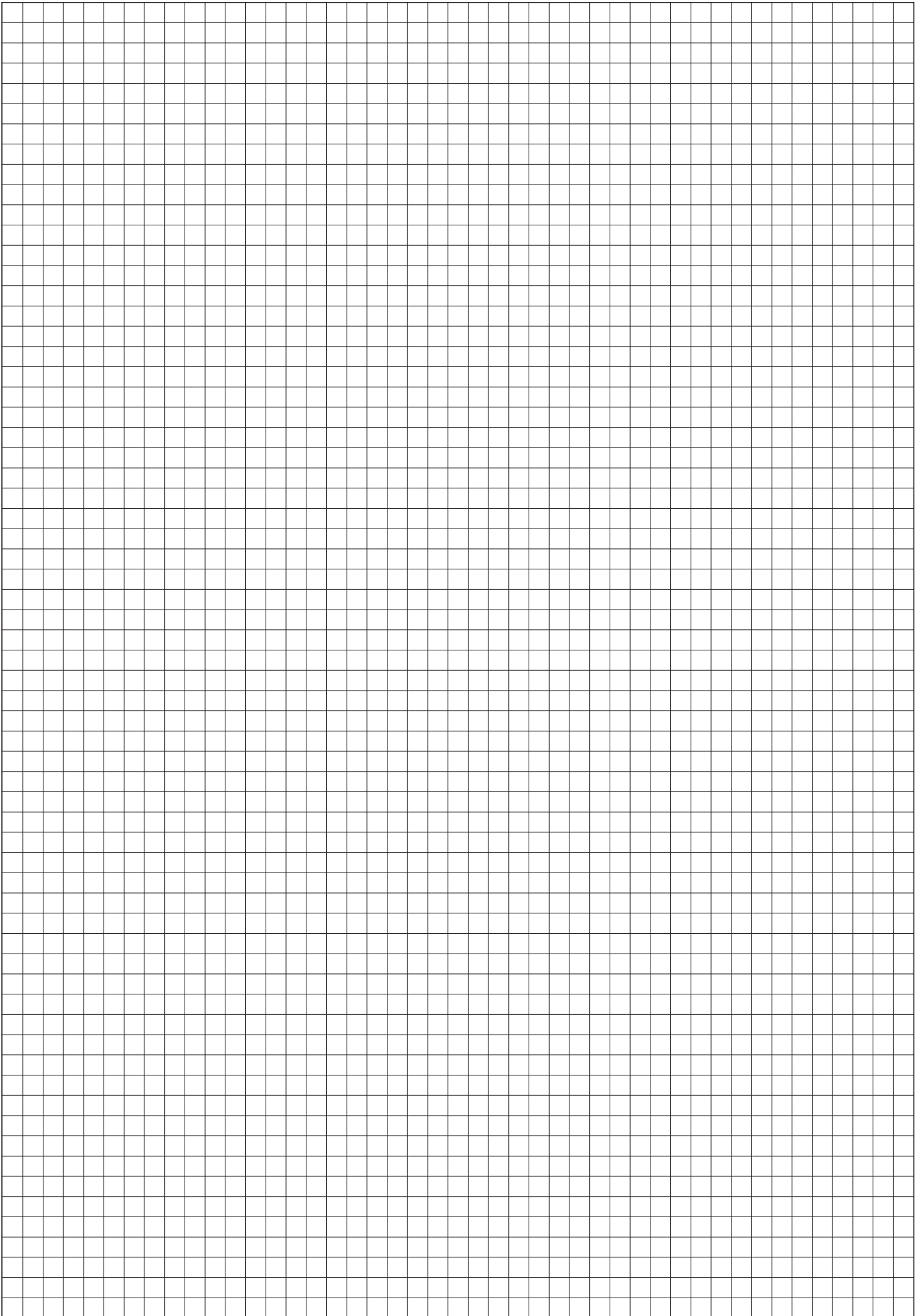

PNEUMAX S.p.A.
24050 Lurano (BG) - Italia
Via Cascina Barbellina, 10

Tel +39 (0) 35 4192777
Fax +39 (0) 35 4192740
+39 (0) 35 4192741

info@pneumaxspa.com
www.pneumaxspa.com

D. NW. 68/IT - 01/2014
PRINTED IN ITALY - 01/2014

